



# Airbus 321 Freighter

Operated by White Airways



# Tailored air cargo solutions

**Global reach, hassle-free delivery:**  
experience the power of our reliable cargo transportation services

**Welcome to Stellavia**, where we redefine air cargo transportation with our commitment to excellence, flexibility, and reliability. As a global provider in the air cargo industry, we offer a wide array of transportation services designed to meet the unique needs of our clients. Whether you're moving time-sensitive medical supplies, high-value goods, perishable items, automotive parts, or e-commerce shipments, our fleet and team are equipped to deliver your cargo safely and on time, anywhere in the world. Our services are tailored to provide the utmost in convenience and efficiency. We offer flexible scheduling options, including fixed and adjustable shipment dates, to accommodate your business demands. With a deep understanding of the complexities of cargo logistics, we handle every shipment with precision and care, adhering to the highest industry standards, including IATA and EASA regulations.

**Efficient and Reliable:**  
Stellavia's A321F for Diverse Cargo Needs.

Stellavia proudly offers top-tier cargo **charter and ACMI** solutions with our state-of-the-art Airbus A321F. Designed for efficiency and reliability, the A321F is the ideal choice for diverse freight needs.

# Key Features

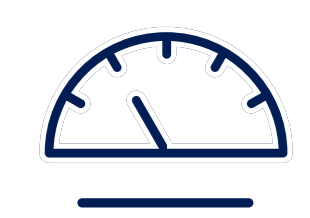

## Lowest Operating Empty Weight (OEW):

The lightest A321-200 freighter conversion available, resulting in a reduced carbon footprint.

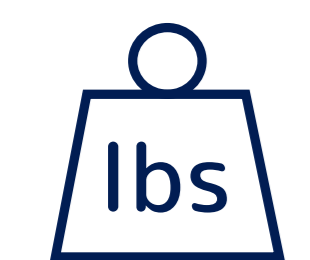

## Payload Capacity:

Approx. 27,000 kg (WV 000), with no OEM weight upgrade prerequisites.



## Fuel Consumption:

Around 2,800 kg per hour at max payload (27 tons)



## Occupant Capacity:

Accommodates 4 + 2 crew members.



## Crew Amenities:

Includes a crew galley with baggage storage and a full-size lavatory.



## Door Configuration:

Retains full-size L1/R1 doors.



## Cargo Volume:

226 m<sup>3</sup>, offering 40 m<sup>3</sup> more than the B737-800F.



## Structural Payload:

Highest standard structural payload for greater flexibility and higher profitability.



## Unique Additional Features:

- ✓ **Enhanced Flight Deck:** Larger flight deck equipped with crew service and lavatory.
- ✓ **Operational Efficiency:** Lower OEW leads to reduced fuel consumption and increased revenue potential.
- ✓ **Loading Flexibility:** 14 ULDs in Main Deck, 10 in Lower Deck
- ✓ **Advanced Loading Options:** Dual locks for PAG netted pallets or 2 AKH's at the 14th position.
- ✓ **Structural Design:** No permanent ballast added, improved center of gravity (CG).
- ✓ **Total Volume:** 226 cubic meters (7,963 Cu. Ft.).
- ✓ **Containerized Volume:** 208 cubic meters.
- ✓ **Cutting-Edge Cargo Technology:** Main deck is equipped with Telair cargo handling system, Telair composite floor panels with integral non-slip surface, reinforced floor beams and OEM lower frames, TSO certified optical detectors, fully recessed LED lighting and smoke detectors.

# Cargo Compartments

## Typical A-Code Payload Arrangement in Main Deck

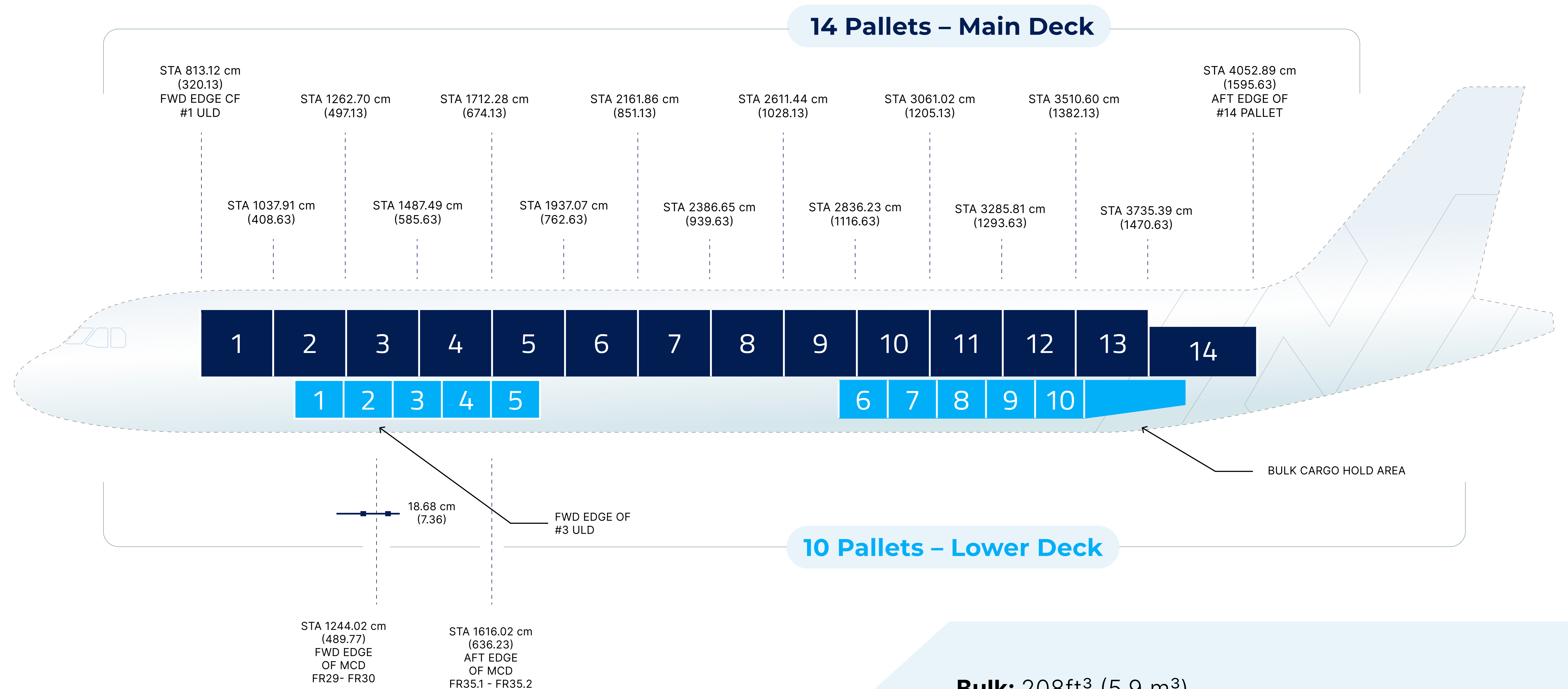

**Bulk:** 208ft<sup>3</sup> (5.9 m<sup>3</sup>)

\* in favour of containerized ULD, water volume, no bulk

# ULD Configuration and Cargo Capacity

## Main deck

- 14 pos. 88" x 125" x 82" (AAY, PAG/PAJ)
- Max. height 82"
- Main Deck Cargo Door (MDCD)  
MDCD Structural Width 3733.8 mm (147 in)  
Width between entrance guides 3510.8 mm (138.2 in)  
Clear Height 2152.7 mm (84.8 in)

## Lower deck

- 10 pos. 60" x 61" x 45" (AKH, PKC)
- Max. height 45"
- Forward- and Aft compartment door:  
(H x W): 46" x 71"
- Compartment 5: Loose cargo only
- Bulk compartment door (H x W): 30" x 36"

## Loading height

- Main deck: Max. 82"
- Lower deck: Max. 45"

## Cargo capacity

- 27,000 kg (61,729 lbs)



# ULD Specification and buildup contour

## PAG

UNIT LOAD DEVICE

CLASSIFICATION:  
PAG, PAA, PAJ, PAP

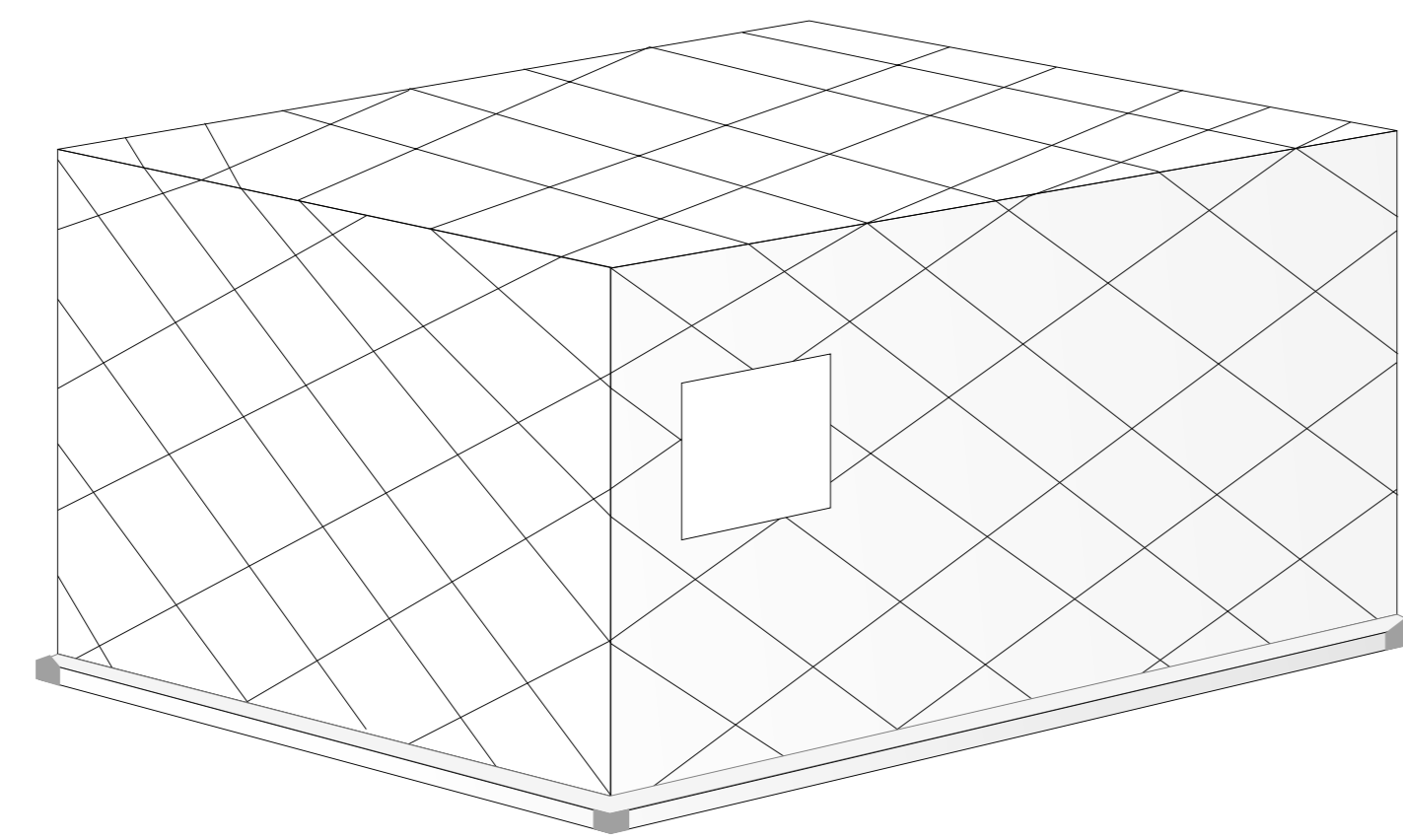

### Dimensions

- **Length** 318cm | 125in
- **Width** 224cm | 88in
- **Height** 163cm | 64in Top N/A
- **Nominal Capacity and Weight**
- **Usable Volume** 10.85m<sup>3</sup> | 383ft<sup>3</sup>

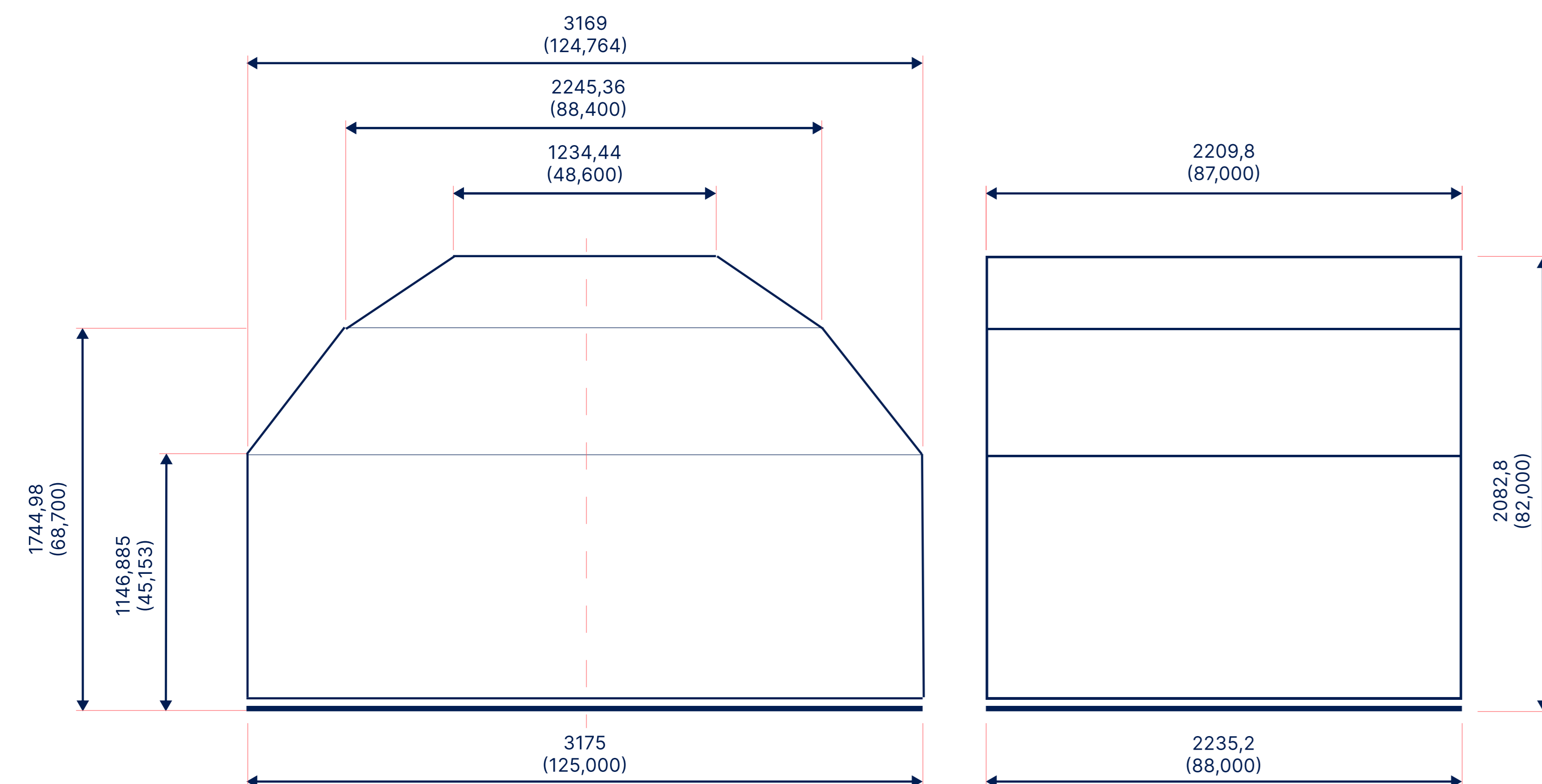

## AKH

UNIT LOAD DEVICE

CLASSIFICATION:  
AKH, LD3-45

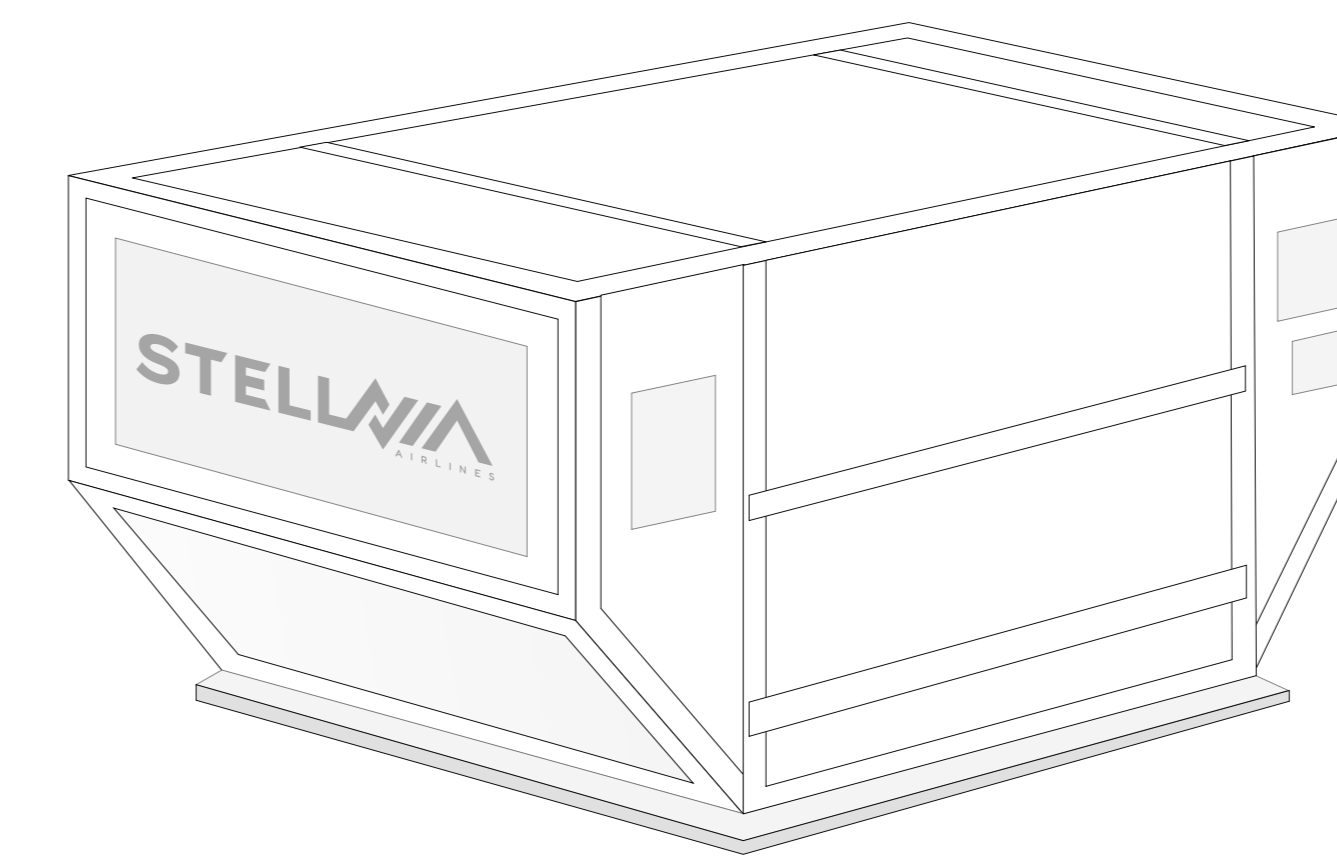

### Dimensions

- **Length** 156cm | 61.5in
- **Width** 153cm | 60.4in
- **Height** 114cm | 45in Top 244cm | 96in
- **Nominal Capacity and Weight**
- **Usable Volume** 3.7m<sup>3</sup> | 131ft<sup>3</sup>
- **Maximum Gross Weight** 1588kg | 3500lbs

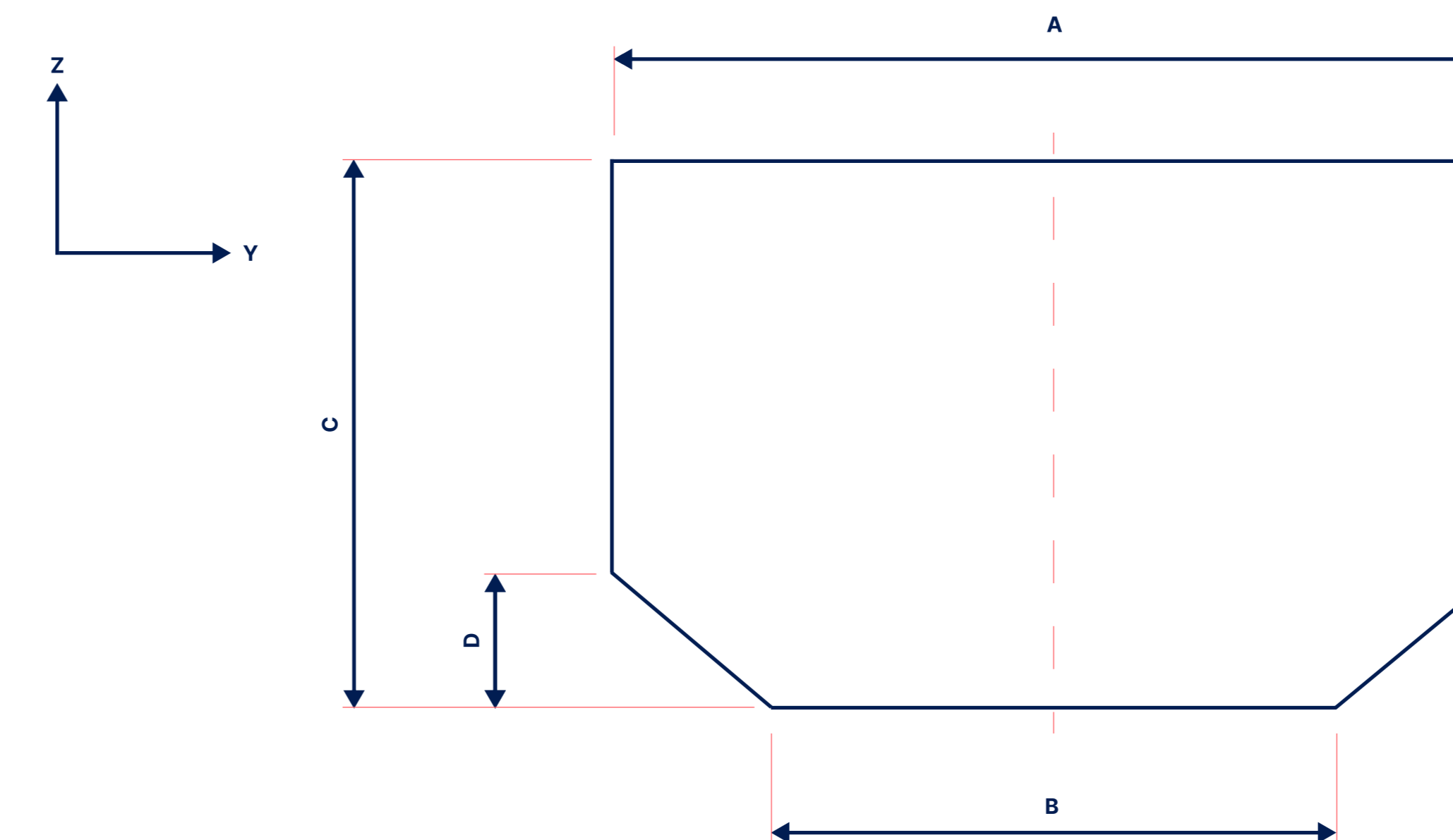

Legend	(m)	(in)
A	2,451	96,50
B	1,562	61,50
C	1,143	45,00
D	0,498	19,60



# Key Benefits and advantages

 **Versatile  
Capacity**

Supports various cargo types, from perishables to oversized goods.

 **Eco-Friendly  
Operations**

Fuel-efficient with sustainable operational practices, minimized environmental impact.

 **Optimal  
Payload**

Payload of up to 27 metric tons and a volume of 208 cubic meters, the A321F offers an excellent balance between cargo volume and weight.

 **Advanced  
Technology**





Equipped with modern avionics and systems, the A321F ensures more efficient flight operations and route planning.

 **Operational  
Efficiency**

Optimized routes and load planning for swift and safe deliveries, ability to operate from a wide range of airports opens up cost-effective routing options.

## Why Choose



-  **Modern Fleet:** cutting-edge Airbus A321F, designed for maximum efficiency and reliability in cargo transport.
-  **Customized Services:** Tailored solutions for specific industries, ensuring seamless logistics.
-  **Dedicated Support:** 24/7 customer service for real-time assistance and updates.
-  **Safety and Compliance:** Stringent adherence to international aviation regulations and best safety practices.
-  **Cost Efficiency:** We offer competitive rates without compromising on quality or service.
-  **Global Reach:** Access to a broad network of destinations, ensuring global reach and timely deliveries.



# Contact Us

We're here to assist you with all your air cargo transportation needs. Contact us today!

 **Phone:** +351 918 450 352

 **Email:** [sales@stella-via.aero](mailto:sales@stella-via.aero)

*Your Cargo, Our Commitment!*